

# STANDARD LOW POWER INDUCTORS

- Designed for general purpose use, switch mode power converters and ripple filters.
- High inductance stability with varying volt-seconds.
- High inductance stability with varying load currents.
- Compact standard packages.
- Choose low profile or vertical.
- Simplified application.

## ELECTRICAL CHARACTERISTICS @25<sup>0</sup>C

Reference Operating Values					Design Control Values			
Low Profile Model No.	Vertical Model No.	Inductance Typical (μH)	I <sub>DC</sub> (1) (Amps)	Max. E <sub>Top(2)</sub> (V-μs)	Inductance No D.C. (μH) Max.	1000 Hz Test Volts No D.C.	DCR (ohms) Max.	Min. Energy Storage (μ J) <sup>(1)</sup>
UT29625	UT29645	150	1.7	80	175	.050	.36	215
UT29626	UT29646	220	1.5	90	255	.070	.38	240
UT29627	UT29647	330	1.0	100	380	.080	.74	165
UT29628	UT29648	470	.90	120	540	.100	1.10	190
UT29629	UT29649	680	.85	175	790	.120	1.25	245
UT29630	UT29650	820	.75	175	950	.130	2.30	230
UT29631	UT29651	1000	.50	175	1150	.140	2.40	125

1. rated for 40°C T rise

2. rated at continuous operation to 20% of I<sub>full</sub>

Green Product



## TYP. INDUCTANCE CHARACTERISTICS

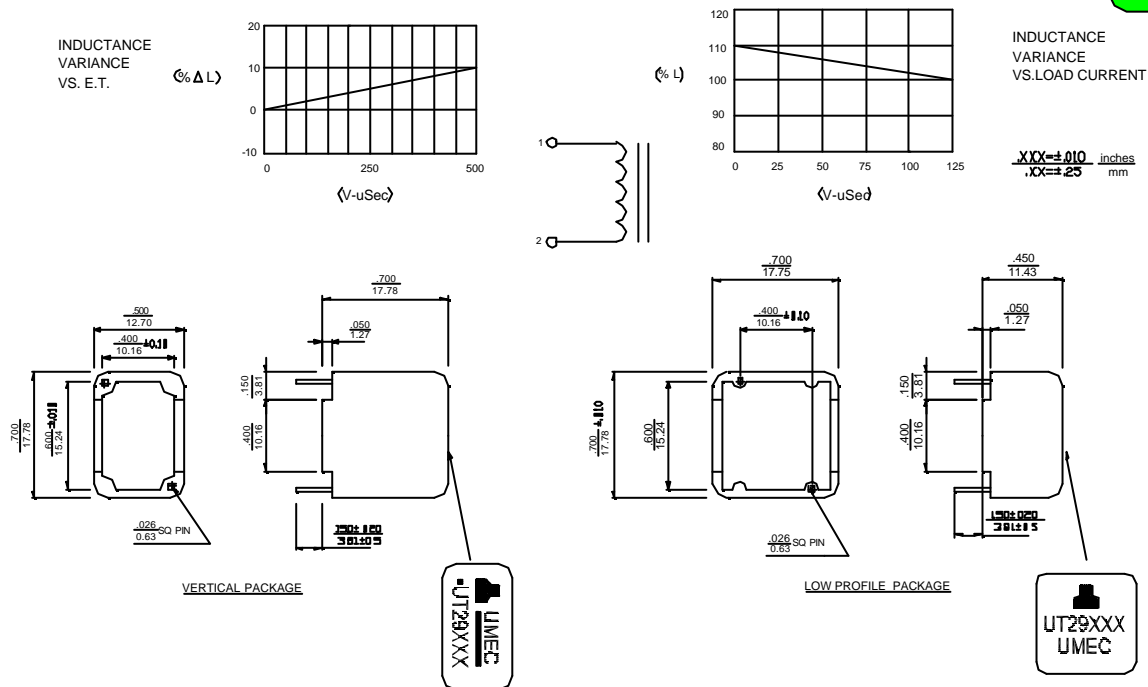

Notes: 1.) Specifications are subject to change without prior notice.

2.) For RoHS compliant products,

a.) The Ordering Code: TG-Model No. ex. TG-UT29625

b.) Date Code suffix to "G" (xxxxG)

DATA SHEET 01-29 JUL./05

1 OF 2



UNIVERSAL MICROELECTRONICS CO., LTD.  
TEL: 886-4-23590096 FAX: 886-4-23590129

3,27TH RD., TAICHUNG INDUSTRIAL PARK,  
TAICHUNG, TAIWAN, R.O.C

# STANDARD LOW POWER INDUCTORS

## TYPICAL APPLICATION

STEP-DOWN

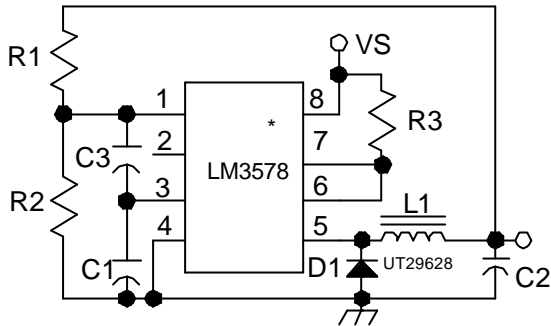

STEP-UP

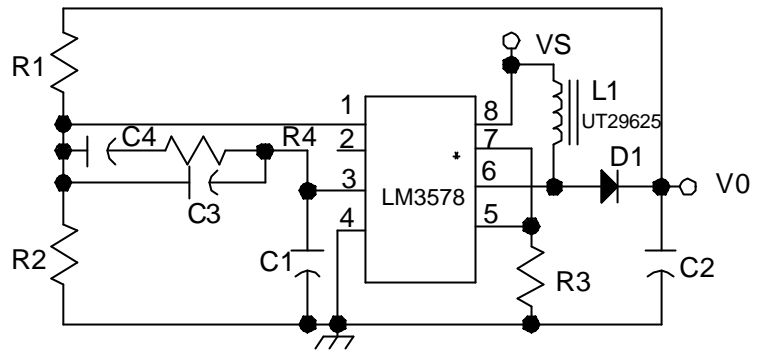

$V_s=15V$        $f_{osc}=50KHz$        $C1=1820pF$   
 $V_o=5V$        $R1=40K\Omega$        $C2=220\mu F$   
 $V_{ripple}=50mV$        $R2=10K\Omega$        $C3=10pF$   
 $I_L=350mA$        $R3=0.1\Omega$        $L1=470\mu H$

$V_s=5V$        $f_{osc}=50KHz$        $R4=220K\Omega$        $C4=0.0022\mu F$   
 $V_o=15V$        $R1=140K\Omega$        $C1=1820pF$        $L1=150\mu H$   
 $V_{ripple}=5mV$        $R2=10K\Omega$        $C2=470\mu F$   
 $I_L=80mA$        $R3=0.1\Omega$        $C3=20pF$

\*Used for Fully Synchronous Operation

\*LM3578 is a National Semiconductor product.

AVERAGING FILTERS		RIPPLE FILTER
FIG. 1 Full or Half Bridge	FIG. 2 Buck Converter	FIG. 3 Flyback Converter
<p> <math>E_{Top} = (V_o + V_d) t_{off}</math>                      Maximum Operating ET occurs at highest input and produces highest core loss.                      DC current must be limited to prevent excessive temperature rise.                 </p>		<p>Operating ET of inductor produces negligible core loss contribution to temperature rise.</p>

DATA SHEET 01-29 JUL./05  
2 OF 2



UNIVERSAL MICROELECTRONICS CO., LTD.  
TEL: 886-4-23590096 FAX: 886-4-23590129

3,27TH RD., TAICHUNG INDUSTRIAL PARK,  
TAICHUNG, TAIWAN, R.O.C