

DATA SHEET

UM MODEL NO.:	SPECIFICATION	REV.	1/1
UT12054	10/100BASE-TX QUAD PORT TRANSFORMER MODULES	A0	05/43

ELECTRICAL SPECIFICATIONS @25⁰C :

Inductance (uH MIN)	Turn Ratio (±2%)	Insertion Loss (dB MAX)	Return Loss (dB MIN @100Ω)				Crosstalk (dB MIN)				Common to Common Rejection Ratio 0.1-60MHz(dB MIN)		Hi-Pot (Vrms) Leakage Current 0.5mA MAX 2sec.
			2-30MHz	40MHz	50MHz	60-80MHz	1MHz	30MHz	60MHz	100MHz	Transmit	Receive	
350	1:1 & 2:1	-1.2	-21	-17	-14.5	-12	-60	-50	-40	-35	-30	-30	1500

Operating temperature is 0°C to 70°C.

DIMENSIONS & SCHEMATIC :

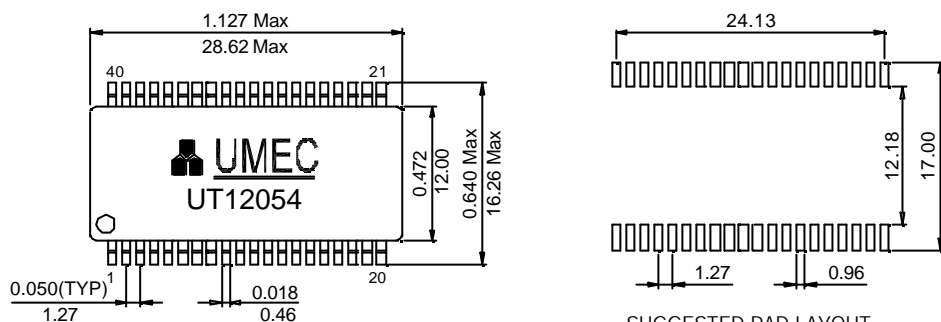

SUGGESTED PAD LAYOUT

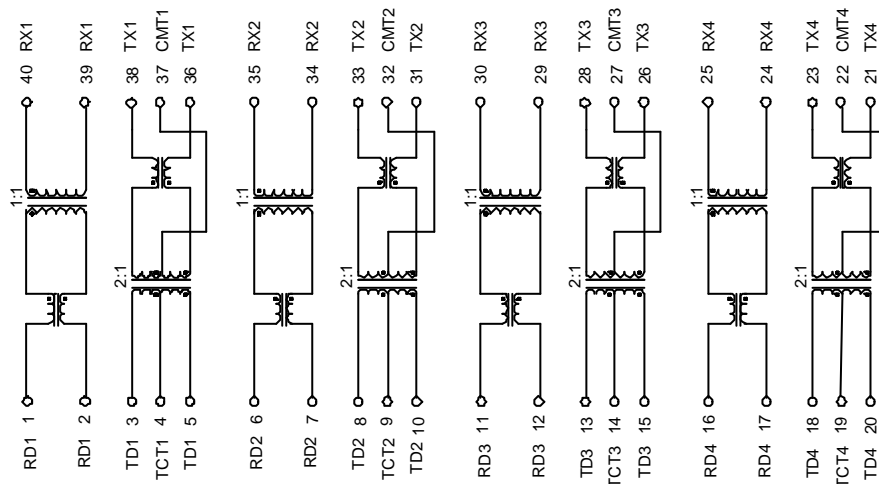
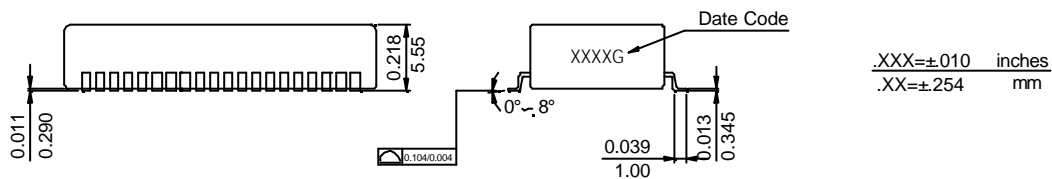

- NOTE: 1. Packaging information-tape and reel according to item no. "SO40" of data sheet 01-00.
 2. For RoHS compliant products:
 a.) UMEC Ordering Code: **TG-UT12054**
 b.) Date Code suffix to "G" (xxxxG).
 c.) Solder: Sn/Ag/Cu.
 3. Specifications are subject to change without prior notice.

