

DATA SHEET

UM PART NO.:	SPECIFICATION	REV.	1/8
UT15105	DUAL TOKEN RING INTERFACE FOR STP AND UTP MEDIA	A0	98/51

Features

- 11111111 » $\bar{0}$ Combines both transmit and receive channels into one module .
 » $\bar{0}$ Same device supports both STP and UTP transmission .
 » $\bar{0}$ Robust matching for excellent return loss .
 » $\bar{0}$ Exceeds IEEE - 802.5 1989 token ring specification for STP cable , and meets current proposal for UTP cable.

Electrical Specifications

(1) Return Loss : (STP 150 Ω Ref. & UTP 100 Ω Ref.)

(I) Transmitter :

-14 dB Min.	-----	4 MHz
-14 dB Min.	-----	8 MHz
-12 dB Min.	-----	16 MHz
-7 dB Min.	-----	24 MHz

(II) Receiver :

-20 dB Min.	-----	4 MHz
-20 dB Min.	-----	8 MHz
-15 dB Min.	-----	16 MHz
-7 dB Min.	-----	24 MHz

(2) Insertion Loss : (STP & UTP)

(I) Transmitter :

-3.0 dB Max.	-----	12KHz
-0.5 dB Max.	-----	1 ~ 4MHz
-2.5 dB Max.	-----	24MHz
-1.0 dB Min.	-----	32MHz
-7.0 dB Min.	-----	37MHz

(II) Receiver :

-3.0 dB Max.	-----	12KHz
-0.5 dB Max.	-----	1 ~ 4MHz
-0.6 dB Max.	-----	8MHz
-0.9 dB Max.	-----	16MHz
-1.5 dB Max.	-----	24MHz
-0.5 ~ -3.0 dB	-----	40MHz
-1.0 dB Min.	-----	50MHz
-15 dB Min.	-----	100MHz

E10-007-B



DATA SHEET

UM PART NO.:	SPECIFICATION	REV.	2/8
UT15105	DUAL TOKEN RING INTERFACE FOR STP AND UTP MEDIA	A0	98/51

(3) Hi-pot : 0.5KVrms 0.5mA 10 sec. , Transmitter & Receiver Input to Output

Dimensions

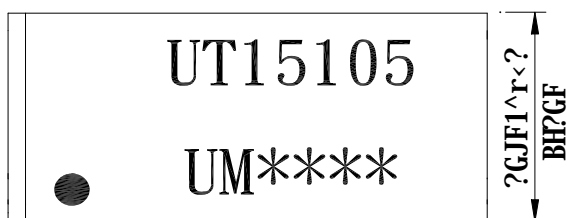

Z€tyv†111?; ; »í1?ABA
^z}}z~v€†v...†111?; ; »í1?CF

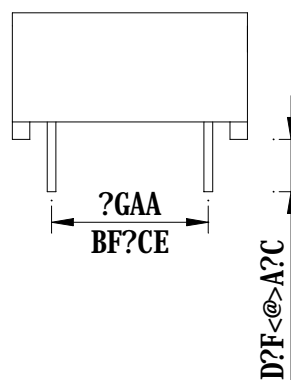
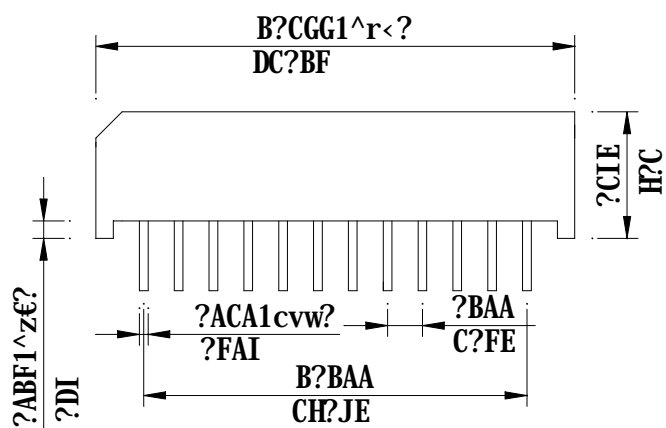

E10-007-B



UNIVERSAL MICROELECTRONICS CO.,LTD.
TEL:886-4-3590096 FAX:886-4-3590129
<http://www.umec-web.com> E-mail:business@umec.com.tw

3,27TH RD.,TAICHUNG INDUSTRIAL PARK,
TAICHUNG,TAIWAN,R.O.C

DATA SHEET

UM PART NO.:	SPECIFICATION	REV.	3/8
UT15105	DUAL TOKEN RING INTERFACE FOR STP AND UTP MEDIA	A0	98/51

Functional Block Diagrams

UT 15105 Receive Side Functional Block

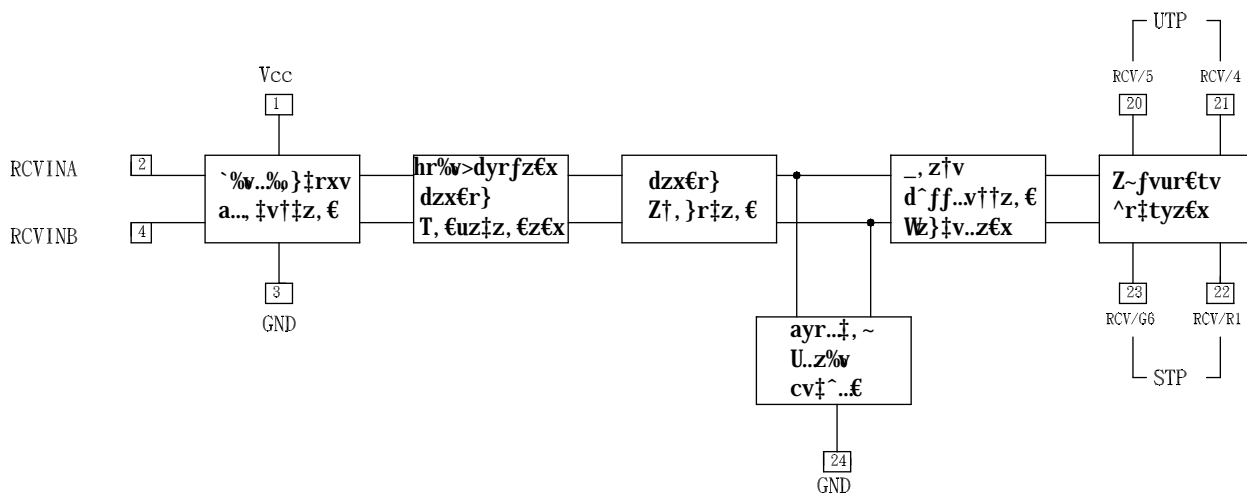

UT 15105 Transmit Side Functional Block

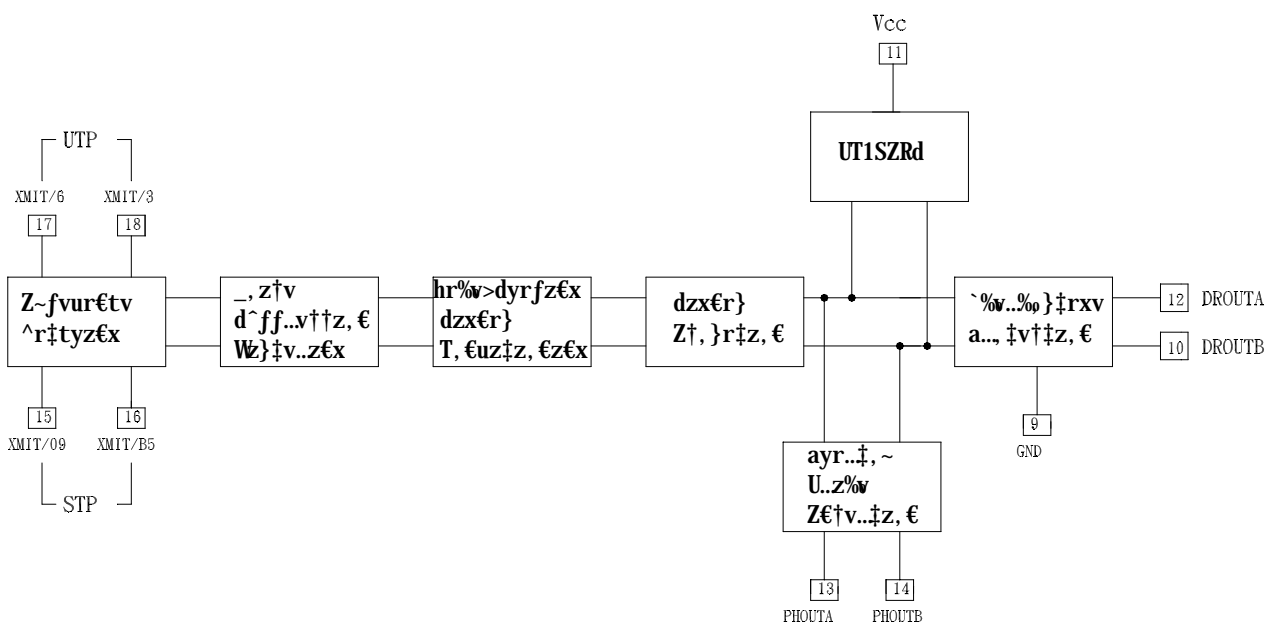

E10-007-B

DATA SHEET

UM PART NO.:	SPECIFICATION	REV.	4/8
UT15105	DUAL TOKEN RING INTERFACE FOR STP AND UTP MEDIA	A0	98/51

Pin Descriptions

Pin #	Symbol	Function / Description
1	Vcc	+5V volt power ($\pm 10\%$). Required for biasing the over voltage protection circuit.
2	RCVINA	Filtered differential manchester receive data to the I. C. connect to Pin 38 of the TMS38054.
3	GND	Ground. Required for biasing the overvoltage protection circuit.
4	RCVINB	Filtered differential manchester receive data to the I. C. connect to Pin 37 of the TMS38054.
9	GND	Ground. Required for biasing the overvoltage protection circuit.
10	DROUTB	Differential manchester transmit data from the I.C. connect to Pin 31 of the TMS38054.
11	Vcc	+5V volt power ($\pm 10\%$). For constant coil bias of the differentially driven center-tapped isolation transformer.
12	DROUTA	Differential manchester transmit data from the I.C. connect to Pin 32 of the TMS38054.
13	PHOUTA	Phantom drive input port, provided for the convenience of transmitting an activated ring insertion command to the concentrator from the front end I.C. connect to Pin 29 of the TMS38054.
14	PHOUTB	Phantom drive input port, provided for the convenience of transmitting an activated ring insertion command to the concentrator from the front end I.C. connect to Pin 27 of the TMS38054.
15	XMIT/09	Filtered, shaping differential manchester transmit data, including phantom drive, to STP ring. Connect directly to the BD-9 Pin 9, or the MIC's orange wire.
16	XMIT/B5	Filtered, shaping differential manchester transmit data, including phantom drive, to STP ring. Connect directly to the DB-9 Pin5, or the MIC'S orange wire.

E10-007-B

DATA SHEET

UM PART NO.:	SPECIFICATION	REV.	5/8
UT15105	DUAL TOKEN RING INTERFACE FOR STP AND UTP MEDIA	A0	98/51

Pin #	Symbol	Function / Description
17	XMIT/6	Filtered, shaping differential manchester transmit data, including phantom drive, to UTP ring. Connect directly to the RJ-45 Pin6.
18	XMIT/3	Filtered, shaping differential manchester transmit data, including phantom drive, to UTP ring. Connect directly to the RJ-45 Pin3.
20	RCV/5	Raw differential manchester receive data, including phantom drive, from UTP ring. Connect directly to the RJ-45 Pin5.
21	RCV/4	Raw differential manchester receive data, including phantom drive, from UTP ring. Connect directly to the RJ-45 Pin4.
22	RCV/R1	Raw differential manchester receive data, including phantom drive, from STP ring. Connect directly to the BD-9 Pin1 or the MIC's red wire.
23	RCV/G6	Raw differential manchester receive data, including phantom drive, from STP ring. Connect directly to the BD-9 Pin6 or the MIC'S green wire.
24	GND	Ground. Allows return path for phantom drive on the receive channel.

»0 Note : All other Pins are not to be connected as they are manufacturing internal test points

E10-007-B



UNIVERSAL MICROELECTRONICS CO.,LTD.
 TEL:886-4-3590096 FAX:886-4-3590129
<http://www.umec-web.com> E-mail:business@umec.com.tw

3,27TH RD.,TAICHUNG INDUSTRIAL PARK,
 TAICHUNG,TAIWAN,R.O.C

DATA SHEET

UM PART NO.: UT15105	SPECIFICATION	REV.	6/8
	DUAL TOKEN RING INTERFACE FOR STP AND UTP MEDIA	A0	98/51

feBFBAlfId`xxvt†wvIdaIRfj}ztr†z, €ITz...t`z†1W...1RIeGfztr}1_, uv

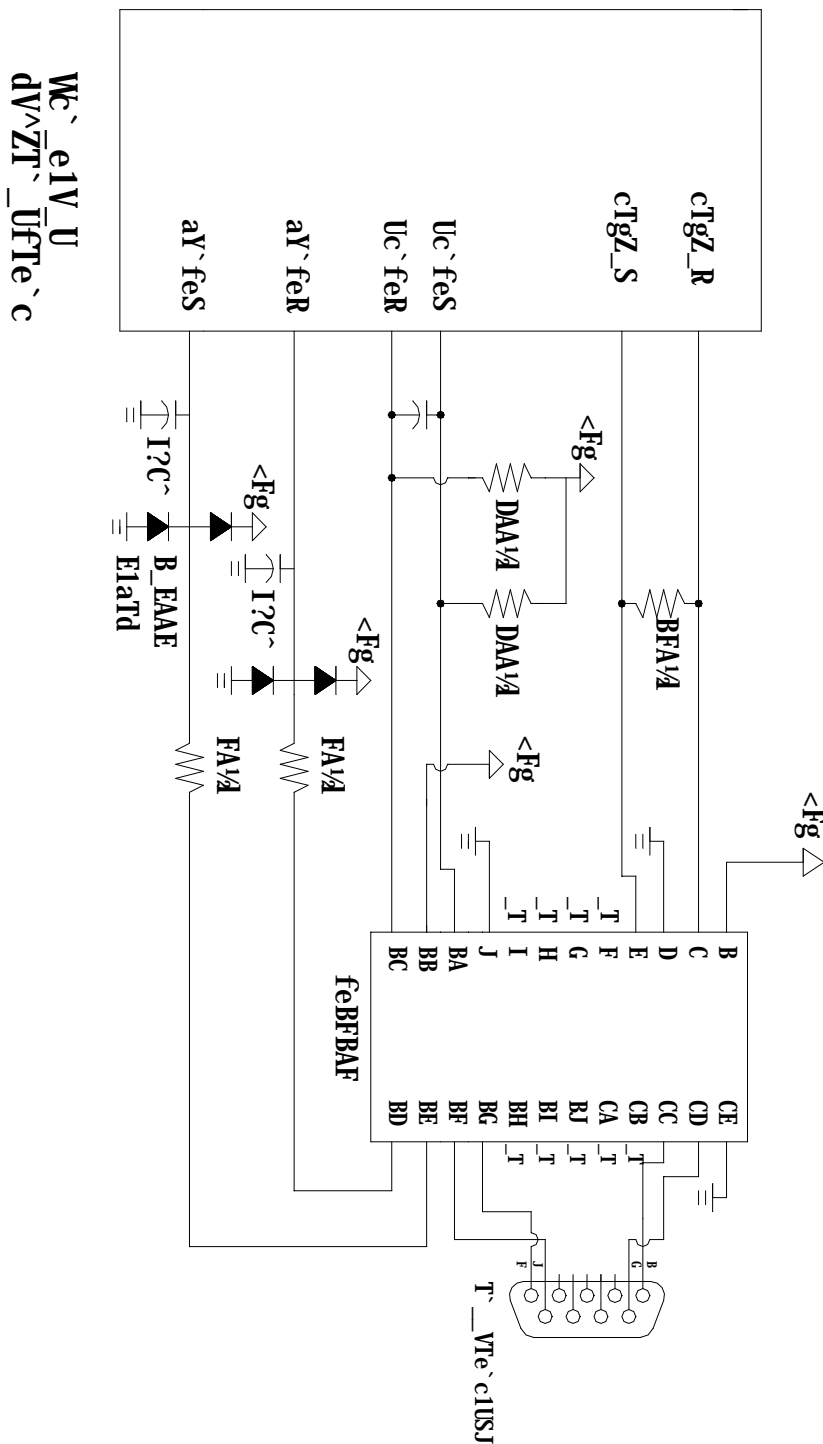

Wc`e1V U
dV^ZT`_UFTe`c

E10-007-B



UNIVERSAL MICROELECTRONICS CO.,LTD.
TEL:886-4-3590096 FAX:886-4-3590129
<http://www.umec-web.com> E-mail:business@umec.com.tw

3,27TH RD.,TAICHUNG INDUSTRIAL PARK,
TAICHUNG,TAIWAN,R.O.C

DATA SHEET

UM PART NO.: UT15105	SPECIFICATION	REV.	7/8
	DUAL TOKEN RING INTERFACE FOR STP AND UTP MEDIA	A0	98/51

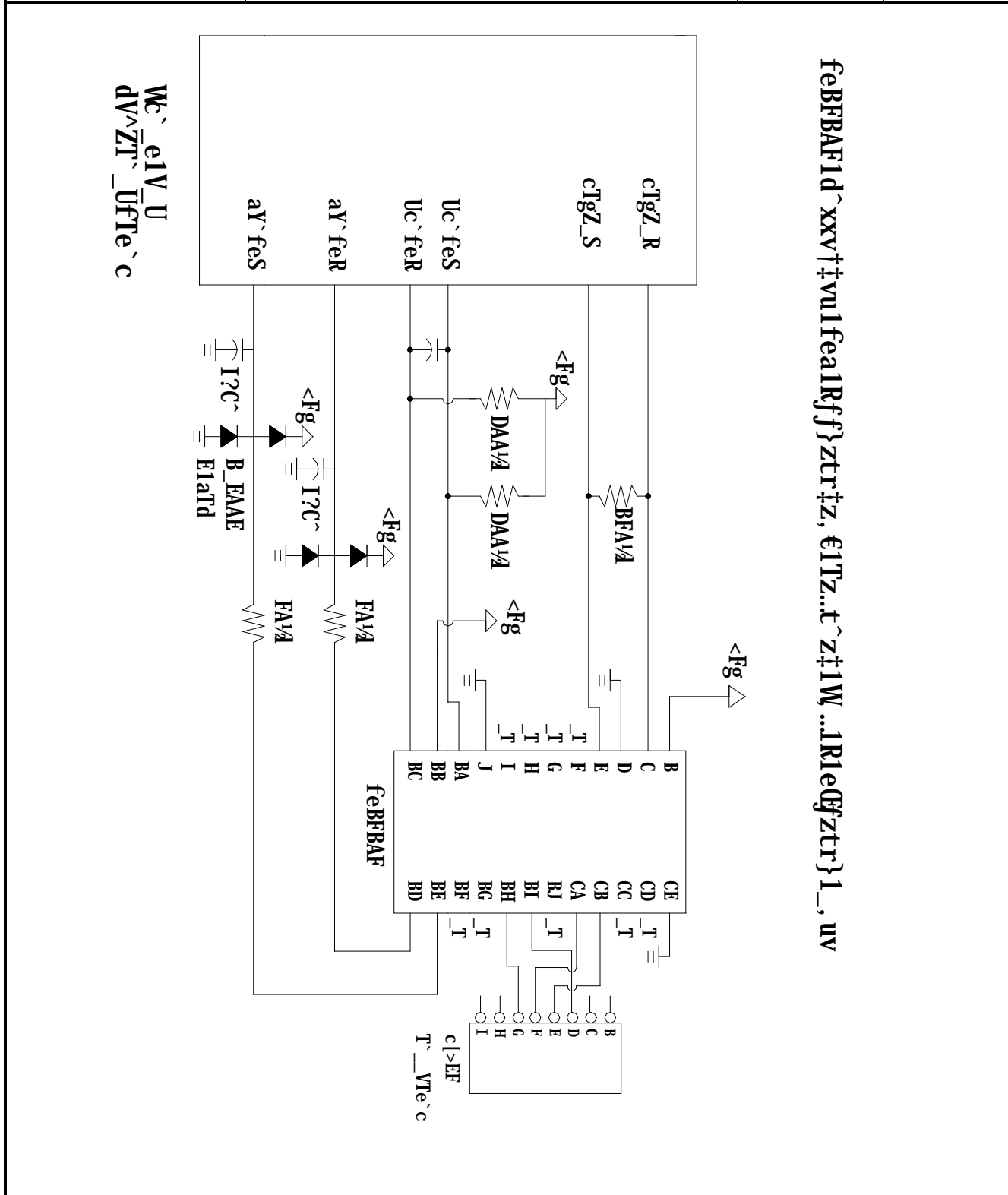

E10-007-B



UNIVERSAL MICROELECTRONICS CO.,LTD.
TEL:886-4-3590096 FAX:886-4-3590129
http://www.umec-web.com E-mail:business@umec.com.tw

3,27TH RD.,TAICHUNG INDUSTRIAL PARK,
TAICHUNG,TAIWAN,R.O.C

DATA SHEET

UM PART NO.:	SPECIFICATION	REV.	8/8
UT15105	DUAL TOKEN RING INTERFACE FOR STP AND UTP MEDIA	A0	98/51

Application Notes

UMEC's transceiver interface module is designed for use with IEEE-802.5 transceiver chips, I.E. TMS38054. The referenced application circuits should serve as a starting point for design. To reduce induced noise. Special attention should be given to the layout of the token ring interface circuitry, especially to the selection of components and their placement.

Transmit

The transmit channel provides a 300Ω impedance to each side of the transceiver IC's output driver. this load represents the impedance reflected through the 2:1 isolation transformer. Signal switching is referenced to Vcc (+5 volts). With surge suppression limits at 0 and 10 volts. The 2:1 isolation transformer interfaces. The IC drivers to a 150ΩEMI filter. The cut-off frequency and phase characteristics of this filter are precisely controlled to maximize the attenuation of signal harmonics above 30MHz, While minimizing signal delay distortion.

Receive

The receive channel consists of a surge suppression network, isolation transformer, low pass filter and common mode choke. The cut-off frequency of the filter has been carefully placed to minimize attenuation and phase distortion on incoming signals, together with the common mode choke, the filter network prevents impulse noise, picked up from the media, from entering the IC receiver input. External terminations allow for module flexibility in achieving high return loss.

Important

Do not connect to both the UTP and STP simultaneously. The module has been optimized to support only one media connection at a time.

Other Applications

The 300Ω termination resistors across Pins 10 and 12 of the transmit channel are recommended for the TMS38054 transceiver chip. The typical capacitive load between these Pins is 8 pf to 9 pf, which includes the chip and PC board. Additional capacitance may be require for other transceiver applications.

E10-007-B



UNIVERSAL MICROELECTRONICS CO.,LTD.
TEL:886-4-3590096 FAX:886-4-3590129
<http://www.umec-web.com> E-mail:business@umec.com.tw

3,27TH RD.,TAICHUNG INDUSTRIAL PARK,
TAICHUNG,TAIWAN,R.O.C