

# ADSL

UM MODEL NO.:	SPECIFICATION	REV.	
UT20132	IMPEDANCE TRANSFORMER	A0	99/42

## ELECTRICAL SPECIFICATIONS AT 25<sup>0</sup>C

1. INDUCTANCE : 0.93 ~ 1.87mH AT 100KHz 100mV , PIN(3-4)
2. TURNS RATIO : (1) 1.125 : 1 ± 1% , AT 15.75KHz 1V , PIN(2-5):(3-4)  
 (2) 2 : 1 ± 1% , AT 15.75KHz 1V , PIN(3-4):(1-6)
3. DC RESISTANCE : (1) 0.245Ω Max. , PIN(2-5)  
 (2) 0.230Ω Max. , PIN(3-4)  
 (3) 0.130Ω Max. , PIN(1-6)
4. HI-POT : 0.5KVrms 0.5mA 2sec. WINDING TO WINDING AND WINDING TO CORE

## DIMENSIONS & SCHEMATICS

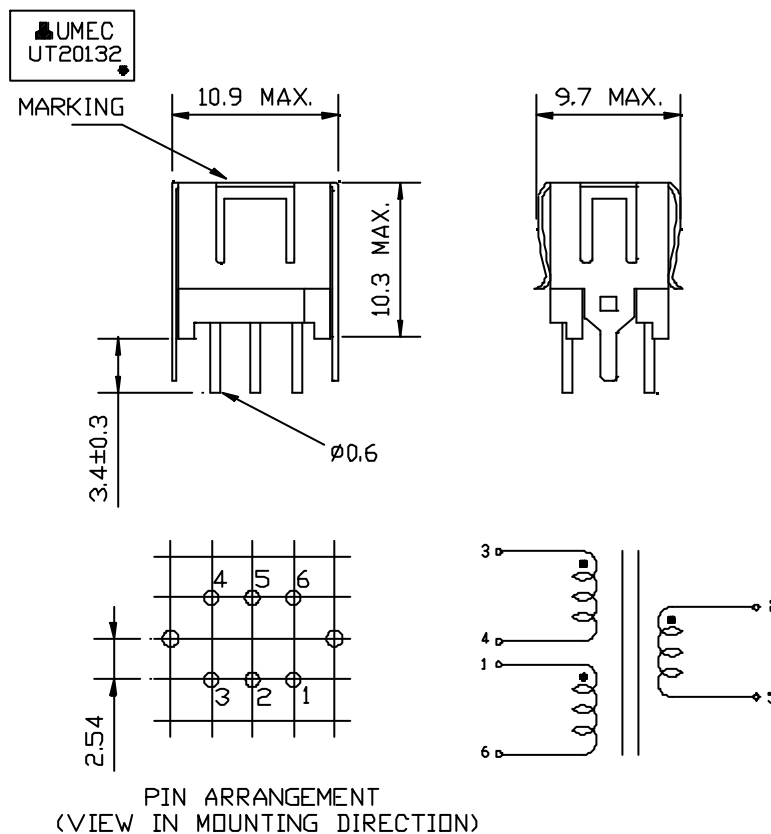

Note: Specifications are subject to change without prior notice.

E10-033-C



UNIVERSAL MICROELECTRONICS CO.,LTD.  
 TEL:886-4-23590096 FAX:886-4-23590129  
<http://www.umec-web.com> Email:business@umec.com.tw

3,27TH RD.,TAICHUNG INDUSTRIAL PARK,  
 TAICHUNG,TAIWAN,R.O.C