

DATA SHEET

UM MODEL NO.:	SPECIFICATION	REV.	
UT30946	WIDEBAND CHOKES	A1	02/39

ELELCTRICAL SPECIFICATION AT 25 °C :

1. INDUCTANCE : 10uH±25% AT 100KHz , 100mV , PIN(1-2).
2. IMPEDANCE : 380Ω TYP. AT 180MHz , 1V , PIN(1-2)

DIMENSION & SCHEMATIC :

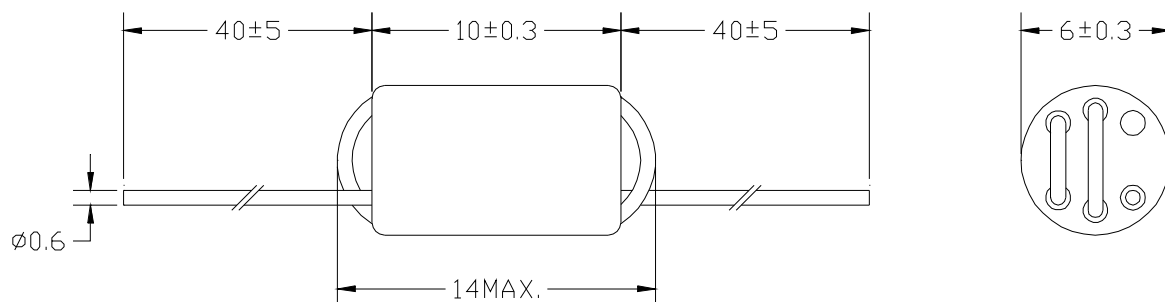

NOTE : specifications are subject to change without prior notice

UNIT : mm



UNIVERSAL MICROELECTRONICS CO.,LTD.
TEL:886-4-23590096 FAX:886-4-23590129
<http://www.umec-web.com> E-mail:business@umec.com.tw

3,27TH RD.,TAICHUNG INDUSTRIAL PARK,
TAICHUNG,TAIWAN,R.O.C

E10-007-C