

DATA SHEET

UM MODEL NO.:	SPECIFICATION	REV.	
UT34297	COMMON MODE CHOKE	A0	01/40

ELECTRICAL SPECIFICATION AT 25⁰C

1. INDUCTANCE : 4.7mH MIN. AT 100KHz , 0.1V , PIN(1-2).
2. D.C.Resistance :
 - (1) 1.0Ω MAX. PIN(1-2).
 - (2) 1.0Ω MAX. PIN(4-3).
3. TURNS RATIO & PHASE: 1:1 AT 15.75KHz , 1V , PIN(1-2):(4-3).
4. COMMON MODE ATTENUATION:
 - (1) 32dB TYP. AT 100KHz , PIN(1-2) // PIN(4-3) , PIN(1-2).
 - (2) 48dB TYP. AT 1MHz , PIN(1-2) // PIN(4-3) , PIN(1-2).
 - (3) 28dB TYP. AT 10MHz , PIN(1-2) // PIN(4-3) , PIN(1-2).
5. DIELECTRIC STRENGTH: 500Vrms/60Hz/0.5mA/2sec PIN(1-2) TO PIN(4-3).

DIMENSION & SCHEMATIC

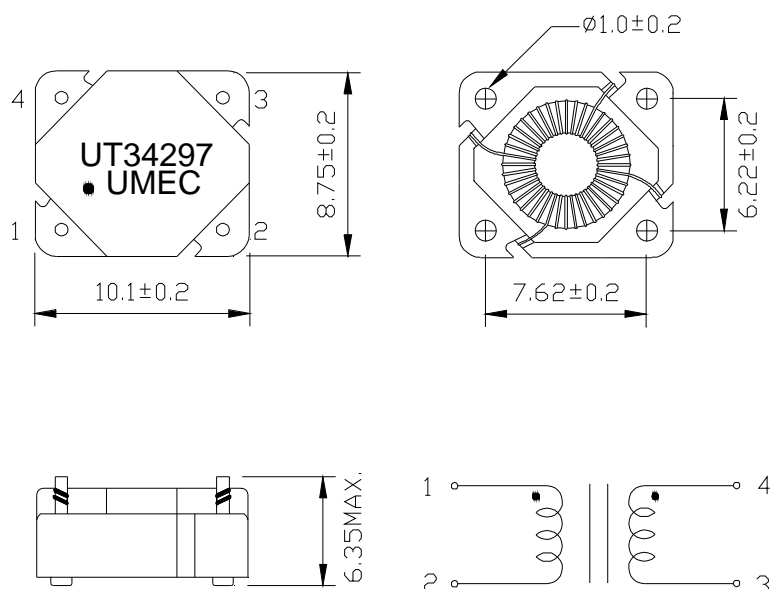

- NOTE: 1.PACKAGING INFORMATION-TAPE AND REEL
 ACCORDING TO ITEM NO. "UM-34297" OF DATA SHEET 01-00
 2.Specifications are subject to change without prior notice.

UNIT : mm

E10-007-C



UNIVERSAL MICROELECTRONICS CO.,LTD.
 TEL:886-4-23590096 FAX:886-4-23590129
<http://www.umec-web.com> E-mail:business@umec.com.tw

3,27TH RD.,TAICHUNG INDUSTRIAL PARK,
 TAICHUNG,TAIWAN,R.O.C