

DATA SHEET

UM MODEL NO.:	SPECIFICATION	REV.	
UT34364	COMMON MODE CHOKE	B0	03/44

ELECTRICAL SPECIFICATIONS AT 25 °C

1. INDUCTANCE : 2.2mH±25% AT 1KHz , 250mV ,PIN(1-4).
2. D.C.Resistance : (1) 25mΩ MAX. PIN(1-4).
(2) 25mΩ MAX. PIN(2-3).
3. TURNS RATIO & PHASE : 1:1 AT 15.75KHz , 1V , PIN(1-4):(2-3).
4. DIELECTRIC STRENGTH: 1500Vrms/60Hz/0.5mA/60sec PIN(1-4) TO PIN(2-3).

DIMENSIONS & SCHEMATIC:

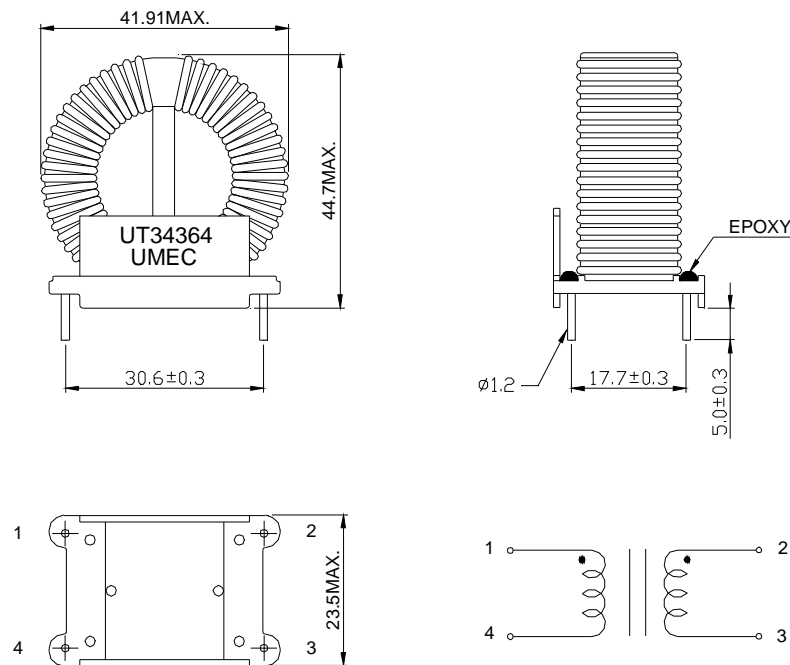

Note: Specifications are subject to change without prior notice.

UNIT : mm.

E10-007-C



UNIVERSAL MICROELECTRONICS CO.,LTD.
 TEL:886-4-23590096 FAX:886-4-23590129
<http://www.umec-web.com> E-mail:business@umec.com.tw

3,27TH RD.,TAICHUNG INDUSTRIAL PARK,
 TAICHUNG,TAIWAN,R.O.C